

## SkyLine Chills

### Blast Chiller-Freezer 20GN2/1 200/170 kg - Remote, Roll-in with UV lamp

ITEM # \_\_\_\_\_

MODEL # \_\_\_\_\_

NAME # \_\_\_\_\_

SIS # \_\_\_\_\_

AIA # \_\_\_\_\_

**727874 (EBFA22URE)**

Skyline Chills Blast Chiller Freezer 200/170kg, 20 GN 2/1 or 600x400mm with touch screen control, UV lamp and remote refrigerating Unit

### Short Form Specification

#### Item No.

Blast chiller freezer with high resolution full touch screen interface, multilanguage

- For GN, 400x600 or Banqueting trolleys.
- Load capacity: chilling 200 kg; freezing 170 kg
- OptiFlow air distribution system to achieve maximum performance
- Chilling/Freezing modes: Automatic (10 food families with 100+ different pre-installed variants); Programs (a maximum 1000 programs can be stored and organized in 16 different categories); Manual (soft chilling, hard chilling, freezing, holding, turbo cooling and lite hot cycles); Specialistic Cycles (Cruise chilling, fast thawing, Sushi&Sashimi, Sous-Vide chilling, ice-cream)
- Special functions: MultiTimer chilling/freezing, Make-it-Mine to customize interface, SkyHub to customize homepage, agenda MyPlanner, SkyDuo connection to SkyLine ovens
- Remaining time estimation for probe-driven cycles based on artificial intelligence techniques (ARTE 2.0)
- Automatic and manual defrosting and drying
- UV lamp for sterilizing cycle
- USB port to download HACCP data, programs and settings. Connectivity ready
- 3-point multi sensor core temperature probe
- Stainless steel construction throughout
- Internal rounded corners
- Remote refrigeration unit (optional accessory).
- R452a refrigerant gas
- Performance guaranteed at ambient temperatures of +43°C (Climatic class 5)
- Compatible with Electrolux, Zanussi and Rational ovens.

### Main Features

- Chilling cycle (+10°C to -41°C) with automatic preset cycles:
  - Soft chilling (air temperature 0°C), ideal for delicate food and small portions.
  - Hard chilling (air temperature -20°C), ideal for solid food and whole pieces.
- X-Freeze cycle (+10°C to -41°C): ideal for blast freezing all kinds of food (raw, half or fully cooked).
- Lite-Hot cycle (+40°C to -18°C): ideal for soft heating preparations.
- Turbo cooling: chiller works continuously at the desired temperature; ideal for continuous production.
- Automatic mode including 10 food families (meat, poultry, fish, sauces and soup, vegetables, pasta/rice, bread, savory and sweet bakery, dessert, beverage fast cooling) with 100+ different pre-installed variants. Through Automatic Sensing Phase the blast chiller optimizes the chilling process according to size, quantity and type of food loaded to achieve the selected result. Real time overview of the chilling parameters. Possibility to personalize and save up to 70 variants per family.
- Cycles+:
  - Cruise Chilling (Patented EP1716769B1 and related family) automatically sets the parameters for the quickest and best chilling (it works by probe)
  - Fast Thawing
  - Sushi&Sashimi (anisakis-free food)
  - Sous-vide chilling
  - Ice Cream
- Programs mode: a maximum of 1000 programs can be stored in the blast chiller's memory, to recreate the exact same high standard at any time. The programs can be grouped in 16 different categories to better organize the menu. 16-step chilling programs also available.
- MultiTimer function to manage up to 20 different chilling cycles at the same time, improving flexibility and ensuring excellent results. Can be saved up to 200 MultiTimer programs.
- 3-point multi sensor core temperature probe for high precision and food safety.
- 6-point multi sensor core temperature probe for maximum precision and food safety (optional accessory).
- Remaining time estimation for probe-driven cycles based on artificial intelligence techniques (ARTE 2.0 Patented US7971450B2 and related family) for an easier planning of the activities.
- Automatic and manual defrosting, drying and sterilizing cycle with UV lamps.
- Performance guaranteed at ambient temperatures of +43°C (Climatic class 5).
- Working temperature from +90°C to +3°C in chilling mode or to -41°C in freezing mode.
- OptiFlow air distribution system to achieve maximum performance in chilling/heating evenness and temperature control thanks to a special design of the chamber.

**APPROVAL:** \_\_\_\_\_

## Construction

- Remote refrigeration unit (optional accessory).
- Environmentally friendly: R452a as refrigerant gas.
- Solenoid valve to automatically manage the gas pressure in the thermodynamic circuit.
- Main components in 304 AISI stainless steel.
- Evaporator with antirust protection.
- Motors and fan waterproof protected IP23.
- Seamless hygienic internal chamber with all rounded corners for easy cleaning.
- Removable magnetic gasket door with hygienic design.
- Ventilator swinging hinged panel for access to the evaporator for cleaning.
- Automatic heated door frame.

## User Interface & Data Management

- High resolution full touch screen interface (translated in more than 30 languages) - color-blind friendly panel.
- Pictures upload for full customization of cycles.
- Make-it-mine feature to allow full personalization or locking of the user interface.
- SkyHub lets the user group the favorite functions in the homepage for immediate access.
- MyPlanner works as an agenda where the user can plan the daily work and receive personalized alerts for each task.
- With SkyDuo the Oven and the Blast Chiller are connected to each other and communicate in order to guide the user through the cook&chill process optimizing time and efficiency (requires optional accessory).
- USB port to download HACCP data, share chilling programs and configurations.
- Connectivity ready for real time access to connected appliances from remote and HACCP monitoring (requires optional accessory).
- Trainings and guidances supporting materials easily accessible by scanning QR-Code with any mobile device.
- Automatic consumption visualization at the end of the cycle.

## Sustainability



- Human centered design with 4-star certification for ergonomics and usability.
- Holding at +3 °C for chilling or -22 °C for freezing, automatically activated at the end of each cycle, to save energy and maintain the target temperature (manual activation is also possible).
- High density polyurethane insulation, 60 mm thickness, HCFC free.
- Zero Waste provides chefs with useful tips for minimizing food waste.  
Zero Waste is a library of Automatic recipes that aims to: give a second life to raw food close to expiration date (e.g.: from milk to yogurt)  
obtain genuine and tasty dishes from overripe fruit/vegetables (usually considered not appropriate for sale)  
promote the use of typically discarded food items (e.g.: carrot peels).

## Included Accessories

- 1 of 3-sensor probe for blast chiller freezer PNC 880582

Front

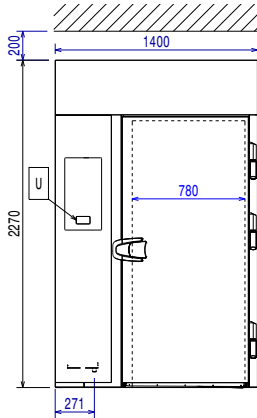

Side

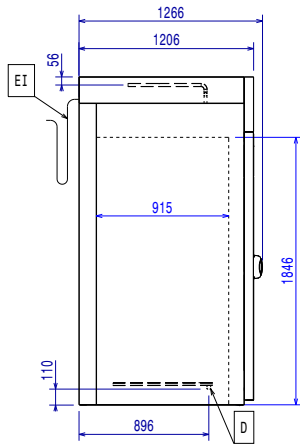

D = Drain  
EI = Electrical inlet (power)  
RO = Refrigerant Outlet

Top

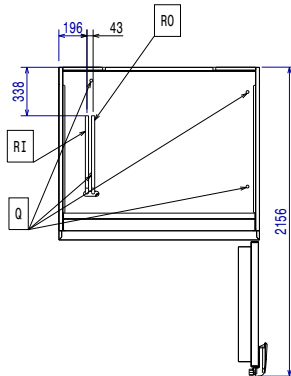

## Electric

<b>Supply voltage:</b>	
727874 (EBFA22URE)	380-415 V/3N ph/50/60 Hz
<b>Electrical power max.:</b>	6.4 kW
<b>Heating power:</b>	6.4 kW
Circuit breaker required	

## Water:

<b>Drain line size:</b>	3/4"
<b>Pressure, bar min:</b>	0

## Installation:

**Clearance:** 5 cm on sides and back.  
Please see and follow detailed installation instructions provided with the unit

## Capacity:

<b>Max load capacity:</b>	200 kg
<b>Trays type:</b>	GN 1/1;GN 2/1;600x400;Ice Cream

## Key Information:

<b>Door hinges:</b>	Right Side
<b>External dimensions, Width:</b>	1400 mm
<b>External dimensions, Depth:</b>	1266 mm
<b>External dimensions, Height:</b>	2270 mm
<b>Net weight:</b>	180 kg
<b>Shipping weight:</b>	190 kg
<b>Shipping volume:</b>	4.81 m <sup>3</sup>

## Refrigeration Data

Remote refrigeration unit required.

<b>Condenser cooling type:</b>	
<b>Suggested refrigeration power:</b>	12650 W
<b>Condition at evaporation temperature:</b>	-20 °C
<b>Condition at condensation temperature:</b>	40 °C
<b>Condition at ambient temperature:</b>	30 °C
<b>Connection pipes (remote) - outlet:</b>	12 mm
<b>Connection pipes (remote) - inlet:</b>	22 mm

Note: refrigeration power calculated at a distance of 20 linear mt.

## ISO Certificates

<b>ISO Standards:</b>	ISO 9001; ISO 14001; ISO 45001; ISO 50001
-----------------------	---

## Sustainability

<b>Refrigerant type:</b>	
<b>GWP Index:</b>	2141
<b>Water consumption:</b>	0 lt/hr

SkyLine Chills  
Blast Chiller-Freezer 20GN2/1 200/170 kg - Remote, Roll-in with UV lamp

The company reserves the right to make modifications to the products without prior notice. All information correct at time of printing.